

# FAST P

VERSIONE SOLO POSTERIORE AL TRATTORE  
 VERSION ONLY REAR THE TRACTOR  
 VERSION UNIQUEMENT À L'ARRIÈRE DU TRACTEUR  
 VERSION NUR DEN TRAKTOR HINTEN

Scalzatore doppio posteriore - Rear double inter row  
 Intercept arrière double - Zweiseitiger stockräumer für hinterseite

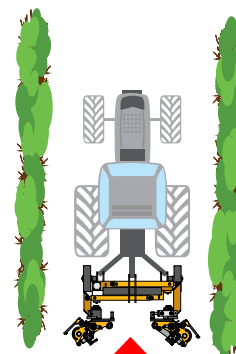

SOLO Posteriore - ONLY Rear -  
 SEULEMENT Arrière - NUR Rückseite

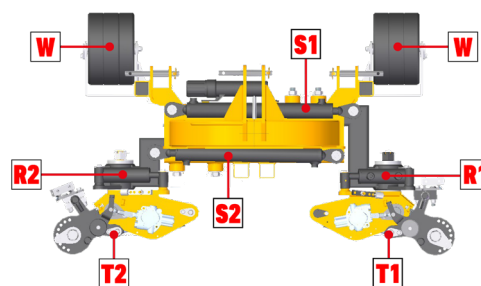

Joystick

Distributore elettroidraulico  
 Electro-hydraulic distributor  
 Distributeur électrohydraulique  
 Elektrohydraulischer Verteiler

Rotazione +35° / -15°  
 Rotation  
 Rotation  
 Drehung



Attacco a tre punti posteriore  
 Rear three-point hitch  
 Attelage trois points arrière  
 Dreipunktaufhängung hinten

OPTIONAL COD. 1A04007

Ruote in gomma - Rubber wheels  
 Roues en caoutchouc - Gummiräder

COD. 1036000J

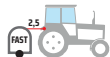

2 MT TUBO DI SERIE | 2 MT PIPE AS STANDARD  
 2 MT TUBE DE SÉRIE | 2 MT ROHR SERIENMÄSSIG

Necessita **SCARICO LIBERO** al trattore!  
 Needs **FREE RETURN LINE** to the tractor!  
 Necessite de **RETOURN LIBRE** a tracteur!  
**FREIES ÖL-ABFLUSSROHR** erforderlich!



## SOLO PER ATTREZZI PASSIVI - FOR NEUTRAL TOOLS ONLY - UNIQUEMENT POUR LES OUTILS PASSIFS - NUR FÜR PASSIVE WERKZEUGE



Joystick



Distributor



Oil - Pressure



COD.	MOD.	MOD.	Movimenti - Movements - Mouvements - Bewegungen	Distributor	Oil - Pressure	Kg
1036000J	6	290				390
1036001J	6	310				400
1036002J	6	350	W	R1 + T1 + S1 R2 + T2 + S2	30 lt/min 180 bar max	415
1036003J	6	400				430
1036004J	6	600				470

OPTIONAL	Descrizione - Description - Description - Beschreibung	Kg
1A04810S	Radiatore - Oil cooler Refrigidisseur - Kühler	*
1A0350300	Valvola ripartitrice di olio per trattori oltre 50 lt/min. - Oil flow valve regulator for tractor over 50 lt/min. Régulateur d'huile pour tracteurs de plus de 50 l/min. - Ölverteilungsventil für Traktoren über 50 l/min.	
1U350007	Kit prolunga tastatore - Extra lower sensor Kit d'extension de palpeur - Sondenverlängerungskit	
1A04007	Maggiorazione ruote in gomma in sostituzione di quelle in ferro - Extra charge for rubber wheels in place of iron ones Supplément des roues en caoutchouc en remplacement des roues en fer - Gummiräder als Ersatz für Räder aus Eisen	

# FAST R

PER TRATTORI CON SOLLEVATORE ANTERIORE E GUIDA REVERSIBILE  
 FOR TRACTORS WITH FRONT LIFT AND REVERSIBLE DRIVE  
 POUR TRACTEURS AVEC RELEVAGE À L'AVANT ET RÉVERSIBLE  
 FÜR TRAKTOREN MIT VORDEREM LIFT UND UMKEHRBAREM ANTRIEB

Scalzatore doppio anteriore/posteriore/reversibile - Front/rear/reversible double inter row  
 Intercept double avant/arrière/réversible - Zweiseitiger stockräumer für vorderseite/hinterseite/umkehrbar

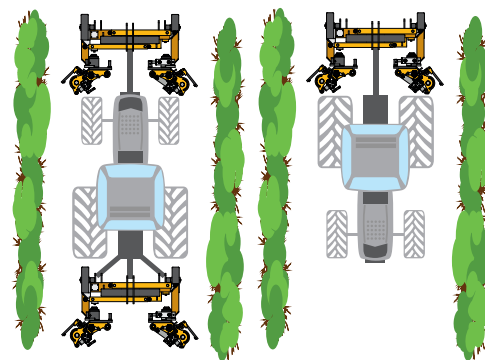

Anteriore/Posteriore - Front / Rear  
 Avant/Arrière - Vorne/Hinten

Trattore reversibile  
 Reversible tractor  
 Tracteur réversible  
 Reversibler Traktor

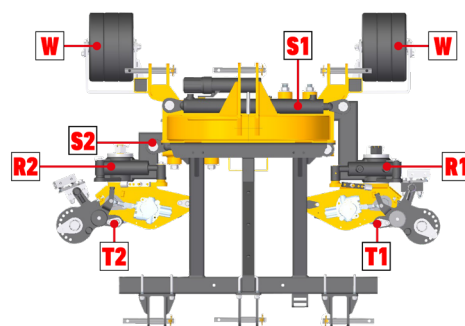

Necessita **SCARICO LIBERO** al trattore!  
 Needs **FREE RETURN LINE** to the tractor!  
 Necessite de **RETOURN LIBRE** a tracteur!  
**FREIES ÖL-ABFLUSSROHR** erforderlich!



Joystick

Attacco a tre punti posteriore  
 Rear three-point hitch  
 Attelage trois points arrière  
 Dreipunktaufhängung hinten

Distributore elettroidraulico  
 Electro-hydraulic distributor  
 Distributeur électrohydraulique  
 Elektrohydraulischer Verteiler

Rotazione +35° / -15°  
 Rotation  
 Rotation  
 Drehung

Tastatore a doppio effetto  
 Double effect sensor  
 Palpeur double effet  
 Doppelleffektsonde

Attacco a tre punti anteriore/reversibile  
 Front/reversible three-point hitch  
 Attelage trois points avant/réversible  
 Dreipunktaufhängung vorne/reversibel

COD. 1035010J

2 MT TUBO DI SERIE | 2 MT PIPE AS STANDARD  
 2 MT TUBE DE SÉRIE | 2 MT ROHR SERIENMÄSSIG

**SOLO PER ATTREZZI PASSIVI - FOR NEUTRAL TOOLS ONLY - UNIQUEMENT POUR LES OUTILS PASSIFS - NUR FÜR PASSIVE WERKZEUGE**



Joystick



Distributor



Oil - Pressure



Kg

COD.	MOD.	MOD.	Movimenti - Movements - Mouvements - Bewegungen	Distributor	Oil - Pressure	Kg
1036010J	6	290				445
1036011J	6	310				450
1036012J	6	350		W	30 l/min 180 bar max	455
1036013J	6	400				470
1036014J	7	600		R1 + T1 + S1 R2 + T2 + S2	30 l/min 180 bar max	495

**\* OBBLIGATORIO PER ATTREZZI MOTORIZZATI SERBATOIO COD. 1A4840 / 41 - MANDATORY FOR TANK POWERED TOOLS COD. 1A4840 / 41**  
**OBLIGATOIRE POUR LES OUTILS ANIMÉ RÉSERVOIR COD. 1A4840 / 41 - OBLIGATORISCH FÜR TANKBETRIEBENE WERKZEUGE COD. 1A4840 / 41**

OPTIONAL	Descrizione - Description - Description - Beschreibung	Kg
1A48040 *	Serbatoio posteriore indipendente con radiatore, pompa Gr.3 e 70 lt olio - Independent oil tank with oil cooler, pump Gr.3 and 70 lt. of oil Réservoir arrière indépendant avec radiateur, pompe Gr.3 et 70 litres d'huile - Unabhängiger hinterer Tank mit Kühler, Gr.3-Pumpe und 70 lt Öl	180
1A48041 *	Serbatoio posteriore indipendente con radiatore, DOPPIA POMPA Gr.3 e 70 lt olio - Independent oil tank with oil cooler, DOUBLE PUMP Gr.3 and 70 lt. of oil Réservoir arrière indépendant avec radiateur, DOUBLE POMPE Gr.3 et 70 litres d'huile - Unabhängiger Öltank mit Ölkühler, DOPPELPUMPE Gr.3 und 70 lt. Öl	190
1A04009	Ruote anteriori Ø 280 x 180 idrauliche con joystick - Hydraulic front wheel Ø 280 x 180 with joystick Roues avant Ø 280 x 180 hydrauliques avec joystick - Vorderräder Ø 280 x 180 hydraulisch mit Joystick	30
1A04007	Maggiorazione ruote in gomma in sostituzione di quelle in ferro - Extra charge for rubber wheels in place of iron ones Supplément des roues en caoutchouc en remplacement des roues en fer - Gummiräder als Ersatz für Räder aus Eisen	
1A0371	Maggiorazione kit tubi 1/2" L. 4,5 MT - Increase of 1/2" hose kit L. 4,5 MT Kit de rallonges de tubes 1/2" L. 4,5 MT - Schlauchanschluss 1/2" L. 4,5 MT	

# FAST S

PER TRATTORI SENZA SOLLEVATORE ANTERIORE  
FOR TRACTORS WITHOUT FRONT LIFT  
POUR TRACTEURS SANS RELEVAGE À L'AVANT  
FÜR TRAKTOREN OHNE VORNE

Scalzatore anteriore doppio flottante - Double front floating inter row  
Intercept double flottant à l'avant - Zweiseitiger stockräumer



Rotazione +35° / -15°  
Rotation  
Rotation  
Drehung

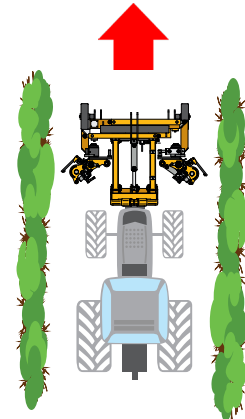

SOLO anteriore - ONLY front - SEULEMENT avant - NUR vorne

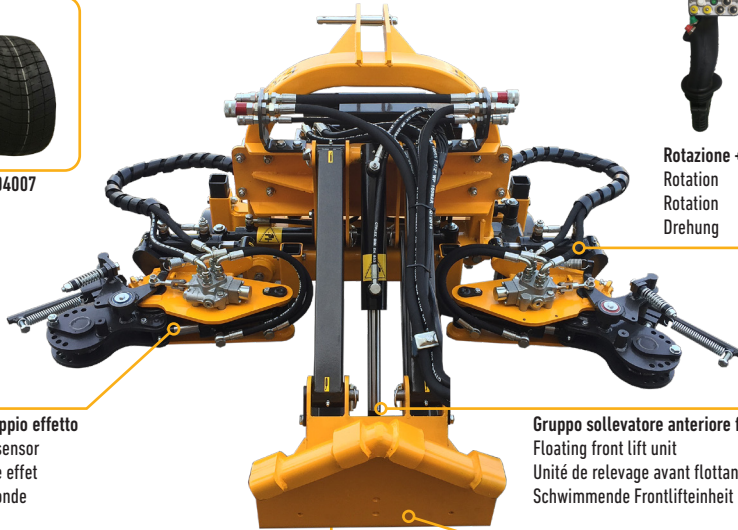
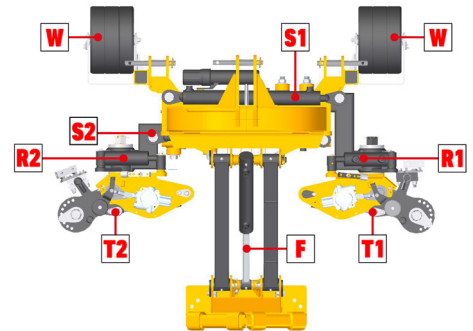

Tastatore a doppio effetto  
Double effect sensor  
Palpeur double effet  
Doppeleffektsonde

Gruppo sollevatore anteriore flottante  
Floating front lift unit  
Unité de relevage avant flottante  
Schwimmende Frontlifteinheit

Aggancio rapido per staffa al trattore  
Quick coupling for bracket to the tractor  
Attelage rapide pour porte-masse au tracteur  
Schnellkupplung für Halterung an den Traktor

COD. 1036020J

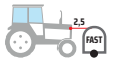

2 MT TUBO DI SERIE | 2 MT PIPE AS STANDARD  
2 MT TUBE DE SÉRIE | 2 MT ROHR SERIENMÄSSIG

Necessita **SCARICO LIBERO** al trattore!  
Needs **FREE RETURN LINE** to the tractor!  
Neccsite de **RETOURN LIBRE** a tracteur!  
**FREIES ÖL-ABFLUSSROHR** erforderlich!



**SOLO PER ATTREZZI PASSIVI - FOR NEUTRAL TOOLS ONLY - UNIQUEMENT POUR LES OUTILS PASSIFS - NUR FÜR PASSIVE WERKZEUGE**



COD.	MOD.	MOD.	Movimenti - Movements - Mouvements - Bewegungen	Distributor	Oil - Pressure	Kg
1036020J	7	290				450
1036021J	7	310				460
1036022J	7	350		W	R1 + T1 + S1 R2 + T2 + S2 + F	475
1036023J	7	400			30 lt/min 180 bar max	485

**\* OBBLIGATORIO PER ATTREZZI MOTORIZZATI SERBATOIO COD. 1A4840 / 41 - MANDATORY FOR TANK POWERED TOOLS COD. 1A4840 / 41**  
OBLIGATOIRE POUR LES OUTILS ANIMÉ RÉSERVOIR COD. 1A4840 / 41 - OBLIGATORISCH FÜR TANKBETRIEBENE WERKZEUGE COD. 1A4840 / 41

OPTIONAL	Descrizione - Description - Description - Beschreibung	Kg
1A04810S	Radiatore - Oil cooler Refrigidisseur - Kühler	4
1A32050	Staffa fissa al trattore (fornire modello e tipo di trattore) - Male connection for tractor (type and version of tractor) Support fixé au tracteur (indiquez le modèle et le type de tracteur) - Am Traktor befestigte Halterung (Modell und Typ des Traktors angeben)	45
1A32051	Staffa fissa maschio grezza - Male quickly connection Support fixe mâle brut - Rohe männliche feste Halterung	25
1A48040 *	Serbatoio posteriore indipendente con radiatore, pompa Gr.3 e 70 lt olio - Independent oil tank with oil cooler, pump Gr.3 and 70 lt. of oil Réservoir arrière indépendant avec radiateur, pompe Gr.3 et 70 litres d'huile - Unabhängiger hinterer Tank mit Kühler, Gr.3-Pumpe und 70 lt Öl	180
1A48041 *	Serbatoio posteriore indipendente con radiatore, DOPPIA POMPA Gr.3 e 70 lt olio - Independent oil tank with oil cooler, DOUBLE PUMP Gr.3 and 70 lt. of oil Réservoir arrière indépendant avec radiateur, DOUBLE POMPE Gr.3 et 70 litres d'huile - Unabhängiger Öltank mit Ölkühler, DOPPELPUMPE Gr.3 und 70 lt. Öl	190
1A04009	Ruote anteriori Ø 280 x 180 idrauliche con joystick - Hydraulic front wheel Ø 280 x 180 with joystick Roues avant Ø 280 x 180 hydrauliques avec joystick - Vorderräder Ø 280 x 180 hydraulisch mit Joystick	30
1A0371	Maggiorazione kit tubi 1/2" L. 4,5 MT - Increase of 1/2" hose kit L. 4,5 MT Kit de rallonges de tubes 1/2" L. 4,5 MT - Schlauchanschluss 1/2" L. 4,5 MT	4,5 MT + 2 MT

# FAST R

PER TRATTORI CON SOLLEVATORE ANTERIORE E GUIDA REVERSIBILE  
 FOR TRACTORS WITH FRONT LIFT AND REVERSIBLE DRIVE  
 POUR TRACTEURS AVEC RELEVAGE À L'AVANT ET RÉVERSIBLE  
 FÜR TRAKTOREN MIT VORDEREM LIFT UND UMKEHRBAREM ANTRIEB

Scalzatore doppio anteriore/posteriore/reversibile - Front/rear/reversible double inter row  
 Intercept double avant/arrière/réversible - Zweiseitiger stockräumer für vorderseite/hinterseite/umkehrbar

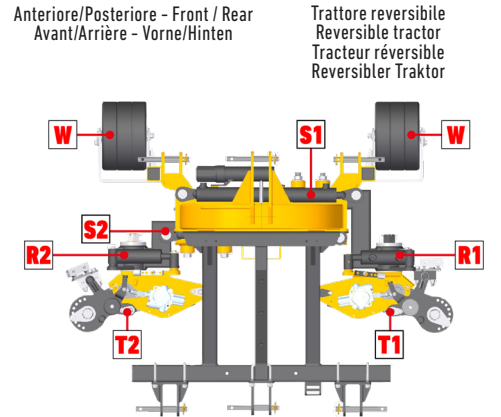
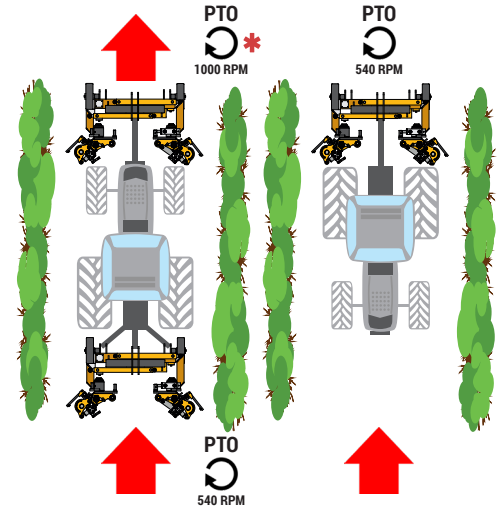
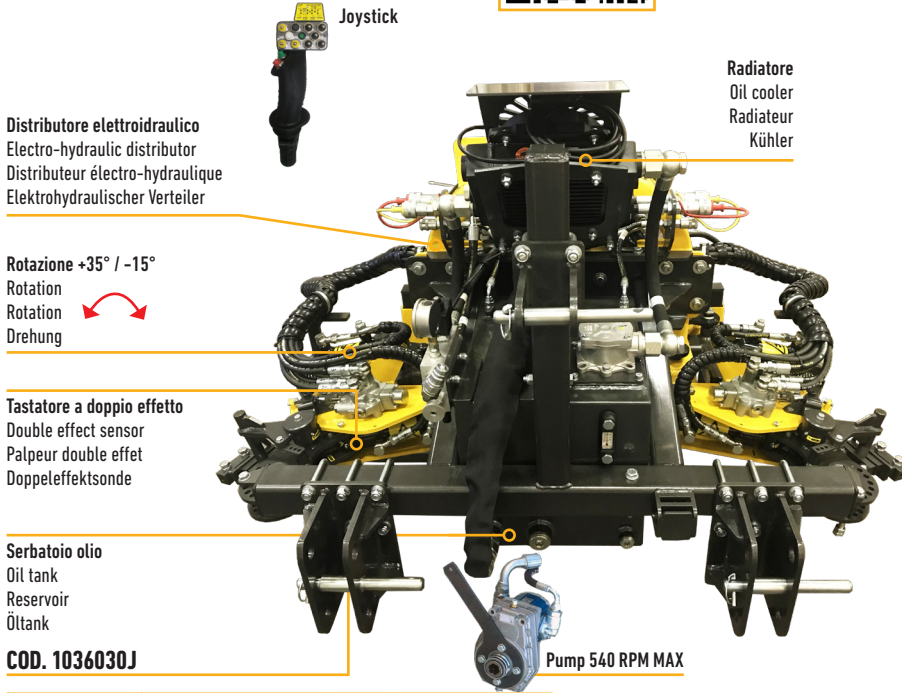

2 MT TUBO DI SERIE | 2 MT PIPE AS STANDARD  
 2 MT TUBE DE SÉRIE | 2 MT ROHR SERIENMÄSSIG

COD.	MOD.	Movimenti - Movements - Mouvements - Bewegungen	Distributor	Oil - Pressure	Kg
1036030J *	6+1 290				580
1036031J *	6+1 310				590
1036032J *	6+1 350	W R1 + T1 + S1 R2 + T2 + S2	+ PTO - 540	30 lt/min 180 bar max PTO 540	600
1036033J *	6+1 400				615
1036034J *	7+1 600				700
1036035J *	7+1 500	R1 + T1 + S1 R2 + T2 + S2 + W	+ PTO - 540	30 lt/min 180 bar max PTO 540	670

\* ALLESTIMENTO PER 1000 RPM SPECIFICARE NELL'ORDINE COD. 1A0367 - EQUIPMENT FOR 1000 RPM SPECIFY IN ORDER COD. 1A0367  
 ÉQUIPEMENT POUR 1000 RPM PRÉCISEZ-LE À LA COMMANDE COD. 1A0367 - AUSRÜSTUNG FÜR 1000 U / min IN DER REIHENFOLGE COD. 1A0367

OPTIONAL	Descrizione - Description - Description - Beschreibung	Kg
1A0350300	Valvola ripartitrice di olio per trattori oltre 50 lt/min. - Oil flow valve regulator for tractor over 50 lt/min. Régulateur d'huile pour tracteurs de plus de 50 l / min. - Ölverteilungsventil für Traktoren über 50 l / min.	
1U350007	Kit prolunga tastatore - Extra lower sensor Kit d'extension de palpeur - Sondenverlängerungskit	
1A04009	Ruote anteriori Ø 280 x 180 idrauliche con joystick - Hydraulic front wheel Ø 280 x 180 with joystick Roues avant Ø 280 x 180 hydrauliques avec joystick - Vorderräder Ø 280 x 180 hydraulisch mit Joystick	30
1A04007	Maggiorazione ruote in gomma in sostituzione di quelle in ferro - Extra charge for rubber wheels in place of iron ones Supplément des roues en caoutchouc en remplacement des roues en fer - Gummiräder als Ersatz für Räder aus Eisen	
1A0370	Maggiorazione kit tubi 1" + 1/2" per fissaggio pompa in PTO 540 rpm Increase of 1" + 1/2" hose kit for pump mounting in PTO 540 rpm Kit de rallonges de tubes 1" + 1/2" pour fixation de pompe en PTO 540 rpm Schlauchaufsatz 1" + 1/2" zur Befestigung der Zapfwellenpumpe 540 rpm	

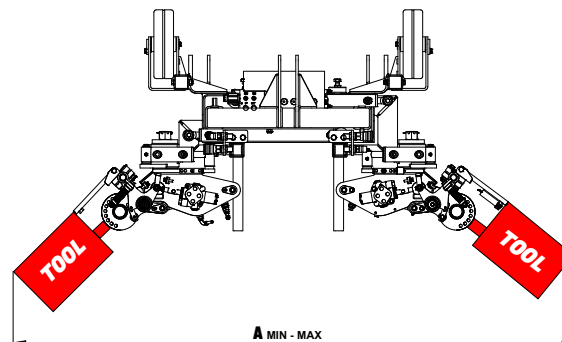
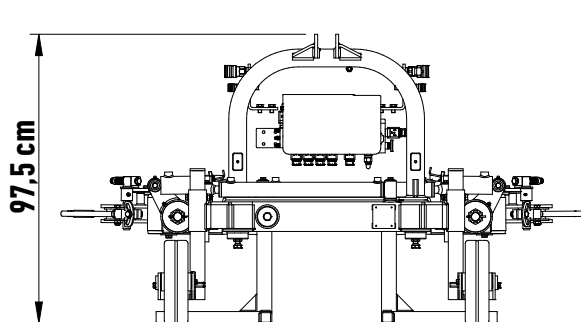

**ATTREZZI PER LA LAVORAZIONE INTERFILARE - INTER-ROW WORKING TOOLS - OUTILS DE TRAVAIL INTERFIL - INTERFIL ARBEITSWERKZEUGE** **Pag. 156**

INGOMBRO CON ATTREZZI DIMENSIONS WITH TOOLS DIMENSIONS AVEC OUTILS ABMESSUNGEN MIT WERKZEUGEN		COD.	MOD. 290 A MIN-MAX [cm]	MOD. 310 A MIN-MAX [cm]	MOD. 350 A MIN-MAX [cm]	INGOMBRO CON ATTREZZI DIMENSIONS WITH TOOLS DIMENSIONS AVEC OUTILS ABMESSUNGEN MIT WERKZEUGEN		COD.	MOD. 290 A MIN-MAX [cm]	MOD. 310 A MIN-MAX [cm]	MOD. 350 A MIN-MAX [cm]
	L 30 cm	<b>1U35330</b>	206 - 292	218 - 308	262 - 372		Ø 45 cm	<b>1U35470</b>	272 - 358	284 - 374	328 - 438
	L 50 cm	<b>1U35340</b>	224 - 310	236 - 326	280 - 390		Ø 60 cm	<b>1U35480</b>	302 - 388	314 - 404	358 - 468
	L 70 cm	<b>1U35350</b>	280 - 366	292 - 382	336 - 446		Ø 80 cm	<b>1U35490</b>	342 - 428	354 - 444	398 - 508
		<b>1U35310</b>	212 - 298	224 - 314	268 - 378		L 60 cm	<b>1U35430</b>	300 - 386	312 - 402	356 - 466
		<b>1U35320</b>					L 80 cm	<b>1U35440</b>	320 - 406	332 - 422	376 - 486
	Ø 30 cm	<b>1U35230</b>	222 - 308	234 - 324	278 - 388			<b>1U35520</b>	338 - 424	350 - 440	394 - 504
	Ø 40 cm	<b>1U35240</b>	232 - 318	244 - 334	288 - 398			<b>1U35530</b>	368 - 454	380 - 470	424 - 534
	Ø 50 cm	<b>1U35250</b>	242 - 328	254 - 344	298 - 408						
	2 el. Ø 31 cm	<b>1U35000</b>	230 - 316	242 - 332	286 - 396		Ø 45 cm	<b>1U35290</b>	238 - 324	250 - 340	294 - 404
	3 el. Ø 31 cm	<b>1U35120</b>	260 - 346	272 - 362	316 - 426		Ø 70 cm	<b>1U35300</b>	262 - 348	274 - 364	318 - 428
	4 el. Ø 31 cm	<b>1U35150</b>	290 - 376	302 - 392	346 - 456		2 el. Ø 36 cm	<b>1U35580</b>	236 - 322	248 - 338	292 - 402
	5 el. Ø 36 cm	<b>1U35156</b>	318 - 404	330 - 420	374 - 484		3 el. Ø 36 cm	<b>1U35590</b>	248 - 334	260 - 350	304 - 414
	1 el. Ø 46 cm	<b>1U35170</b>	194 - 280	206 - 296	250 - 360		4 el. Ø 36 cm	<b>1U35610</b>	260 - 346	272 - 362	316 - 426
	2 el. Ø 46 cm	<b>1U35180</b>	228 - 314	240 - 330	284 - 394		Ø 54 cm	<b>1U355000</b>	250 - 336	262 - 352	306 - 416
	3 el. Ø 46 cm	<b>1U35190</b>	262 - 348	274 - 364	318 - 428		Ø 70 cm	<b>1U355060</b>	268 - 354	280 - 370	324 - 434
	L 30 cm	<b>1U35450</b>	208 - 294	220 - 310	264 - 374		Ø 100 cm	<b>1U355080</b>	332 - 418	344 - 434	388 - 498
	L 60 cm	<b>1U35460</b>	224 - 310	236 - 326	280 - 390		L 30 cm	<b>1U35513</b>	224 - 310	236 - 326	280 - 390
	L 60 cm	<b>1U35421</b>	266 - 352	278 - 368	322 - 432		L 60 cm	<b>1U35510</b>	232 - 318	244 - 334	288 - 398
	L 80 cm	<b>1U35420</b>	282 - 368	294 - 384	338 - 448						



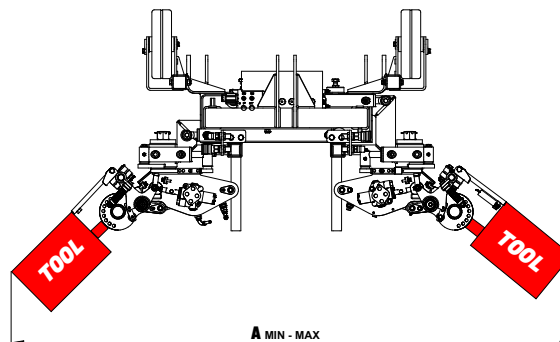
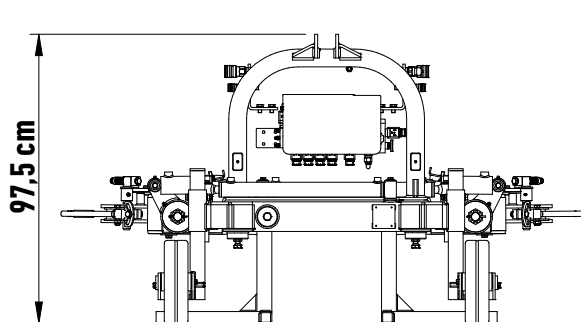

**ATTREZZI PER LA LAVORAZIONE INTERFILARE - INTER-ROW WORKING TOOLS - OUTILS DE TRAVAIL INTERFIL - INTERFIL ARBEITSWERKZEUGE** Pag. 156

INGOMBRO CON ATTREZZI DIMENSIONS WITH TOOLS DIMENSIONS AVEC OUTILS ABMESSUNGEN MIT WERKZEUGEN		COD.	MOD. 400 A MIN-MAX [cm]	MOD. 500 A MIN-MAX [cm]	MOD. 600 A MIN-MAX [cm]	INGOMBRO CON ATTREZZI DIMENSIONS WITH TOOLS DIMENSIONS AVEC OUTILS ABMESSUNGEN MIT WERKZEUGEN		COD.	MOD. 400 A MIN-MAX [cm]	MOD. 500 A MIN-MAX [cm]	MOD. 600 A MIN-MAX [cm]
	L 30 cm	<b>1U35330</b>	308 - 418	260 - 420	366 - 566		Ø 45 cm	<b>1U35470</b>	374 - 484	326 - 486	432 - 632
	L 50 cm	<b>1U35340</b>	326 - 436	278 - 438	384 - 584		Ø 60 cm	<b>1U35480</b>	404 - 514	356 - 516	462 - 662
	L 70 cm	<b>1U35350</b>	382 - 492	334 - 494	440 - 640		Ø 80 cm	<b>1U35490</b>	444 - 554	396 - 556	502 - 702
		<b>1U35310</b>	314 - 424	266 - 426	372 - 572		L 60 cm	<b>1U35430</b>	402 - 512	354 - 514	460 - 660
		<b>1U35320</b>					L 80 cm	<b>1U35440</b>	422 - 532	374 - 534	480 - 680
	Ø 30 cm	<b>1U35230</b>	324 - 434	276 - 436	382 - 582		Ø 45 cm	<b>1U35290</b>	340 - 450	292 - 452	398 - 598
	Ø 40 cm	<b>1U35240</b>	334 - 444	286 - 446	392 - 592		Ø 70 cm	<b>1U35300</b>	364 - 474	316 - 476	422 - 622
	Ø 50 cm	<b>1U35250</b>	344 - 454	296 - 456	402 - 602						
	2 el. Ø 31 cm	<b>1U35000</b>	332 - 442	284 - 444	390 - 590		2 el. Ø 36 cm	<b>1U35580</b>	338 - 448	290 - 450	396 - 596
	3 el. Ø 31 cm	<b>1U35120</b>	362 - 472	314 - 474	420 - 620		3 el. Ø 36 cm	<b>1U35590</b>	350 - 460	302 - 462	408 - 608
	4 el. Ø 31 cm	<b>1U35150</b>	392 - 502	344 - 504	450 - 650		4 el. Ø 36 cm	<b>1U35610</b>	362 - 472	314 - 474	420 - 620
	5 el. Ø 36 cm	<b>1U35156</b>	420 - 530	372 - 532	478 - 678						
	1 el. Ø 46 cm	<b>1U35170</b>	296 - 406	248 - 408	354 - 554		Ø 54 cm	<b>1U355000</b>	352 - 462	304 - 464	410 - 610
	2 el. Ø 46 cm	<b>1U35180</b>	330 - 440	282 - 442	388 - 588		Ø 70 cm	<b>1U355060</b>	370 - 480	322 - 482	428 - 628
	3 el. Ø 46 cm	<b>1U35190</b>	364 - 474	316 - 476	422 - 622		Ø 100 cm	<b>1U355080</b>	434 - 544	386 - 546	492 - 692
	L 30 cm	<b>1U35450</b>	310 - 420	262 - 422	368 - 568		L 30 cm	<b>1U35513</b>	326 - 436	278 - 438	384 - 584
	L 60 cm	<b>1U35460</b>	326 - 436	278 - 438	384 - 584		L 60 cm	<b>1U35510</b>	334 - 444	286 - 446	392 - 592
	L 60 cm	<b>1U35421</b>	368 - 478	320 - 480	426 - 626						
	L 80 cm	<b>1U35420</b>	384 - 494	336 - 496	442 - 642						

